

SyncServer S350

Ultra Precise & Versatile GPS Network Time Server

KEY FEATURES

- Ultra High-Bandwidth NTP Time Server
- Stratum 1 Operation via GPS Satellites
- Gigabit Ethernet port plus 3 additional Independent 10/100Base-T Ports
- Internal Dial-up Modem for Time Reference Redundancy
- Independent Time References: GPS, Timecodes, 1PPS, 10 MHz
- Versatile Timing Outputs: IRIG A/B/E/G/NASA36/XR3/2137 AM or DCLS, 1PPS, 10 MHz, Sysplex
- Stratum 2 Operation via NTP Servers
- RADIUS, NTPv4 Autokey, MD5 Authentication
- Secure Web-Based Management
- SSH, SSL, SCP, SNMP, Custom MIB, HTTPS, Telnet, and More
- IPv6 and IPv4 Compatible
- Nanosecond Time Accuracy to UTC
- Alarm Relays
- Rubidium & OCXO Oscillator Upgrades
- Upgrade to Radio Broadcast Time Sync
- Optional T1/E1 Input/Output

KEY BENEFITS

- Synchronize Thousands of Client, Server & Workstation Clocks
- Very Reliable and Secure Source of Time for Your Network
- Multiple NTP Ports for Easy Network Configuration and Adaptation
- Extremely Accurate Time Source for Network Synchronization
- Enhanced Network & Security Features
- User Prioritized Reference Selection between, GPS, Timecode, 1PPS and 10 MHz
- Access Multiple Time Sources for Reliable and Secure Time
- Intuitive Web Interface for Easy Control & Maintenance

Setting new standards for security, reliability, redundancy and versatility in network time servers, the SyncServer® S350 GPS Network Time Server is the solution for synchronizing the time on servers and workstations for large or expanding IT enterprises. Accurately synchronized clocks are critical for network log file accuracy, security, billing systems, electronic transactions, database integrity, VoIP, and many other essential applications.

The S350 continues the SyncServer legacy of being the easiest to set up and maintain network time servers in the world. The front panel is designed to quickly bring the server online with a few front panel keystrokes or DHCP. To fully configure the unit, use the very intuitive web interface or the step-by-step web-based wizards for the most common operations.

Once online, the S350 provides very reliable and secure network synchronization technology by combining multi-port network interfaces with multiple time reference technology and enhanced security protocols. Support of essential security and network protocols provide for easy management and seamless integration into your existing and future network.

The S350 is the only time server available with a Gigabit Ethernet port plus three additional 10/100Base-T ports. This translates into high availability and throughput to support

hundreds of thousands of network clients while maintaining microsecond caliber NTP timestamp accuracy. These four completely independent ports provide the flexibility needed to easily adapt to different and changing network topologies and security requirements.

The Stratum 1 S350 will automatically synchronize to GPS, IRIG, 1PPS, and 10 MHz sources. Users can set the priority and the S350 will smoothly transition from one reference to the next if the higher priority signal is lost or regained. An internal modem will synchronize to dial-up time sources if local references are not available. The S350 can also revert to a Stratum 2 mode and retrieve time from other user-designated time servers. Similarly the S350 generates many timecodes, 1PPS and 10 MHz outputs and can be upgraded to an internal Rubidium atomic oscillator that keeps the S350 accurate to microseconds per day. Optionally, T1/E1 inputs/outputs are available as is an AM radio to synchronize to national time broadcasts.

The SyncServer S350 is your answer to bringing perfect timing to your network – securely, reliably and easily – and for many years to come.

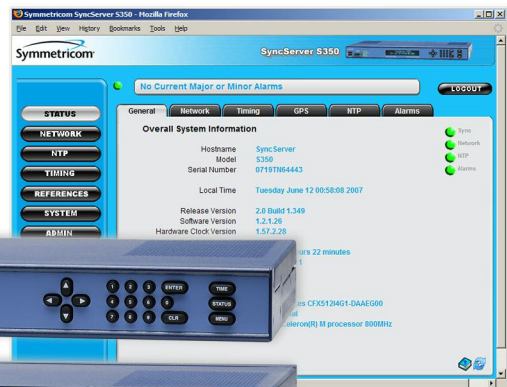

S350 NETWORKING EXCELLENCE

Gigabit Ethernet for Unmatched High Performance with Unparalleled Flexibility

The S350 has four dedicated and isolated Ethernet ports, one of which is Gigabit Ethernet. These are connected to a very high-speed microprocessor and a 50 nanosecond accurate clock to assure unparalleled high bandwidth NTP performance. This more than meets the need of servicing 7000 NTP requests per second while maintaining microsecond caliber timestamp accuracy.

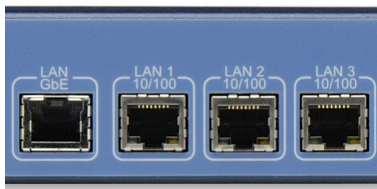

Four network ports (including Gigabit) provide network configuration flexibility and enhanced security. "Multiple" isolated and synchronized time servers can also be configured.

Four Ports for Flexibility and Security

Multiple ports provide the flexibility to adapt to different network topologies as networks grow and change. An S350 can be the single time source to synchronize clients that are on different subnets and different physical networks. It is also an ideal solution for synchronized time on in-band and out-of band networks. Since each port is independent,

BEST PRACTICES

- Always configure time clients to reference at least two time servers.
- Two time servers provide redundant time source protection for time clients.
- Peering between time servers assures time continuity to time clients if other time sources are not available.
- Increase network security by serving time via ports GbE, 2 and 3 and reserving port 1 for management only.

it can appear as though there are four clocks available, even though there is only a single time reference. In security sensitive networks we suggest using one port for maintenance and control functions and the other three ports for NTP timing functions only. This way the control port IP address information can be kept private and not distributed with the NTP addresses. IP address access control lists for each port also add enhanced security.

Extensive Protocol Support for Secure and Easy Network Integration and Management

All of the expected network management and monitoring protocols are standard in the S350. Secure access protocols such as RADIUS, SSL, HTTPS, SSH, along with legacy protocols such as DHCP and Telnet are included to provide you a choice in server management. SNMP v3 with a custom MIB allows you to automatically monitor the S350 and be advised of any important status changes. Any of these protocols can be quickly and easily disabled via the web based management interface.

Futureproof Your Network

The S350 supports both IPv4 and IPv6. The S350 works whether you are using IPv4, IPv4/IPv6 mixed-mode, or the IPv6 environment. This means your S350 can scale with your network operations and provide value for many years to come.

Automatic Software Upgrade Availability Notification

The S350 can periodically check the Symmetricom web site for newer versions of firmware. If a newer version is available, an informational SNMP trap or email is sent along with a status message in the web interface.

Point & Click Software Upgrades

Upgrading the firmware in the S350 is easy. Just browse to identify the firmware file and click the upload button. It is just as simple to backup and restore the server configuration files. This intuitive approach simplifies server management.

Time Server Log Files

A running log of activity and server configuration changes is maintained for later reference.

Examples of Network Timing Configurations



Basic configuration

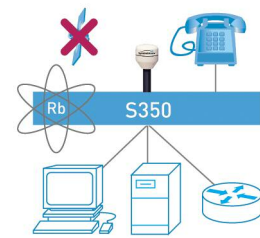

Resilient configuration incorporating a Rubidium Oscillator for improved holdover performance.

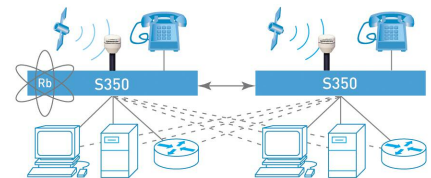

Redundant, resilient and secure configuration incorporating a Rubidium Oscillator in the primary server and peering to another server for backup redundancy.

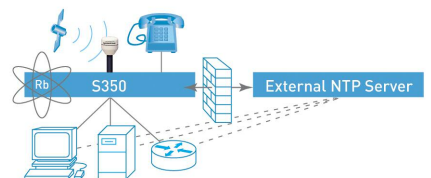

Resilient internal configuration. However, security, accuracy and reliability risks exist when peering with an external time server through the firewall.

S350 ADVANCED AND FUNCTIONAL DESIGN

- Very high-speed processor for superior NTP server performance
- 7000 NTP requests per second with microsecond caliber time stamp accuracy
- Easily upgradeable firmware via web interface (simple point & click)
- High reliability, wide range power supply (AC or DC)
- No fan
- No hard drive
- 12 channel GPS receiver with single satellite timing for urban canyon environments
- Timecodes. 1PPS, 10 MHz inputs and outputs
- Optional T1/E1 inputs and outputs
- 4 ports: 1x Gigabit Ethernet, 3x 10/100Base-T
- 2x Alarm Relays
- Radio Ready low Frequency Radio option
- Modem for backup time reference
- Optional Oscillators
 - Rubidium atomic oscillator option for 3 μ s per day holdover accuracy
 - OCXO oscillator option for 1 ms per day holdover accuracy

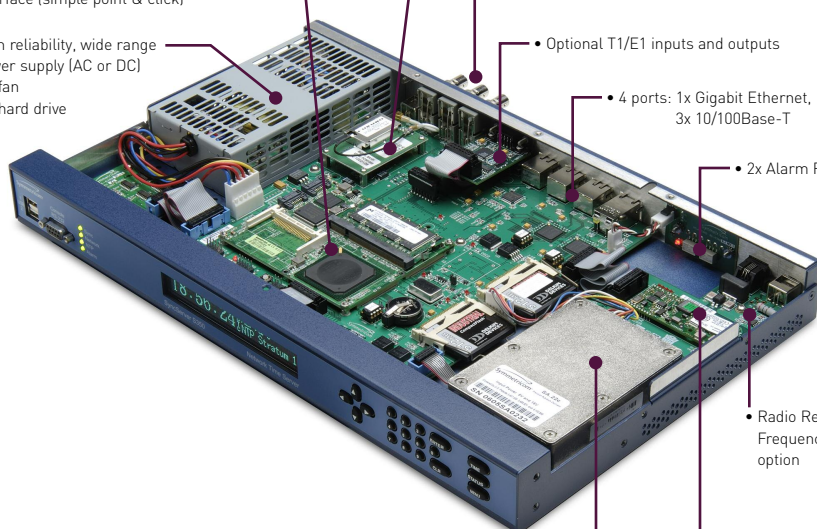

Alarm Relays for Monitoring Systems

The S350 features in-depth internal monitoring, very flexible configurations, and external alarming. Alarm relays are one of several ways the unit can report alarm conditions to an alarm monitoring system. One relay is activated if power to the server is ever lost. The other relay is user configurable to activate if there is any major alarm, or any major/minor alarm.

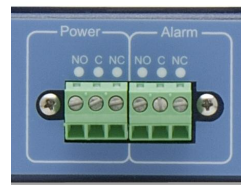

User configurable alarm relays for major/minor alarms as well loss-of-power alarm relay.

Control at Your Finger Tips

The interface on the S350 has been developed and tested from a user perspective. Keypad operation is quick and easy when using the full numeric keypad and control keys. You can cycle through different time formats by pressing the [TIME] key or get detailed status information by pressing the [STATUS] key. The S350 offers front panel menu control via the [MENU] button.

Quick and Easy Installation

The S350 has been optimized for quick setup via the keypad, requiring a minimum number of keystrokes. Just enter the basic network parameters or select DHCP and the unit is online. Once online,



The full numeric keypad is the most efficient way to navigate a menu driven interface. The [TIME] & [STATUS] buttons quickly display the most critical information.

the web interface is the best and easiest way to customize the time server.

Primary configuration and management of the S350 is done via the intuitive and easy-to-use web interface. It is the first time server that offers wizards to streamline common setup and management tasks. No other time server is available with such an effortless interface that provides intuitive navigation and depth of control.

Crisp, Bright Display and LEDs

Whether you need to view time information close-up or far away, the 256x32 high-resolution, variable intensity vacuum fluorescent display provides high visibility time and status in a variety of user selectable formats. The 1, 2 or 4 line display of data makes for a crystal clear time display along with an informative presentation of important configuration information. The four LEDs provide at-a-glance status of the current time reference, network connection status, NTP operational status and request activity, and any existing alarm situation.



Crisp and bright vacuum fluorescent display offers high readability both near and far. Characters can be large, medium or small. Intensity is user adjustable.



Informative Status LEDs provide at-a-glance health of the network time server. The USB ports add additional flexibility in back-up, restore and upgrade operations.

BEST PRACTICES

- A full numeric keypad with a display makes for quick initial setup and installation.
- Most interactions with a time server are remote and are best served with a full featured web interface and good SNMP monitoring.

S350 FULL-FEATURED WEB INTERFACE

Intuitive, Easy-to-Use and Secure

The S350 is designed to have the web interface be the primary status and control console. It is organized into logical groupings such as Status, Network, Timing, etc. The tabbed panels offer easy exploration of features and

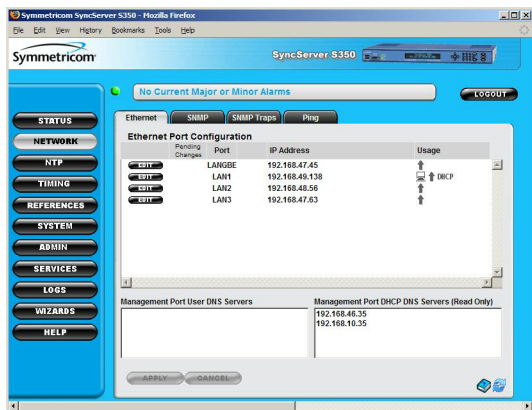

easy configuration of the server. Typical web interface conventions are followed so that operation is quickly mastered. Server access is password protected, with a choice of RADIUS authentication and SSL encryption for maximum security. The web interface is enabled only through Port 1 so that the user may choose to keep that port IP address exclusive and secure while serving time protocols only from Ports 2, 3 and/or GbE.

Wizards Speed Routine Server Configuration Tasks

The S350 includes wizards to guide you step-by-step through the more frequent or expected operations. From experience we know there are certain configuration activities that most customers will, at some point, want to perform with the

server. These include initial set-up, configuring time source behaviors, back-up and restore operations, firmware upgrades, and more. The wizards make these operations very easy. Like all systems that include wizards, you can use the detailed configuration pages elsewhere in the web interface for custom configuration of the server.

Built-in Help System

The complete S350 manual is built into the web interface. The manual opens in a separate browser window. It is organized to match the control buttons and tabs so that information is quickly and easily found. On most pages there is a link directly to the manual page for that panel.

In addition there are context sensitive rollover descriptors of various features and tabs on any given panel.

Full System Status and Log Files

An essential part of a time server is knowing the system status when you need to. The S350 provides a semi-customizable green/red/orange light status with system messages for quick, at-a-glance information. Detailed status information is available on all of the major subsystems of the server via the tabbed panels in the Status section.

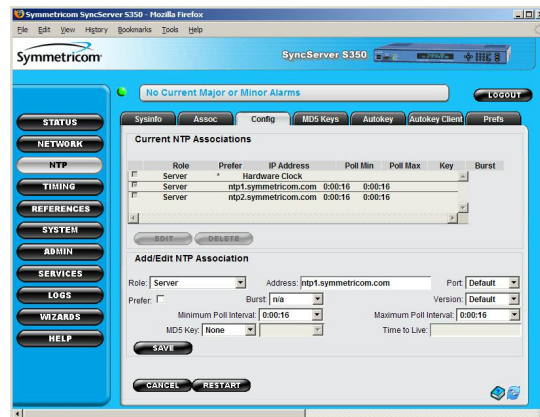
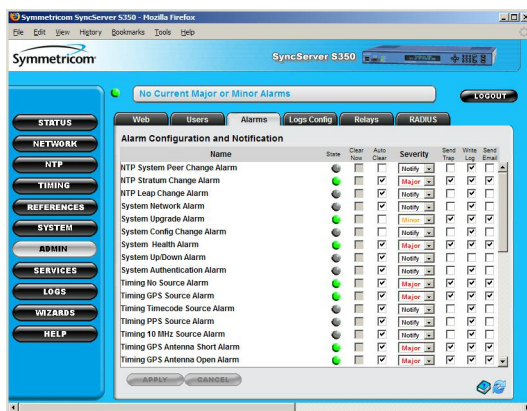

Any alarms or critical alerts are quickly found on the Alarm panel. To examine operational events, the Log section of the web interface provides detailed listings of System, NTP, SNMP, HTTP, and Event activities.

BEST PRACTICES

- **Configuring a time server is generally done once and seldom repeated. For that reason it should be easy to configure and maintain.**
- **Consider the importance of quick and easy configuration back-up and restore operations, as well as the simplicity of firmware upgrades.**
- **Web based wizards save time and eliminate configuration conflicts. Easy configuration of advanced features is also important.**
- **Turning on the auto-notification of firmware update availability assures awareness of current firmware revisions.**

S350 TRUSTED SOURCE FOR NETWORK TIME

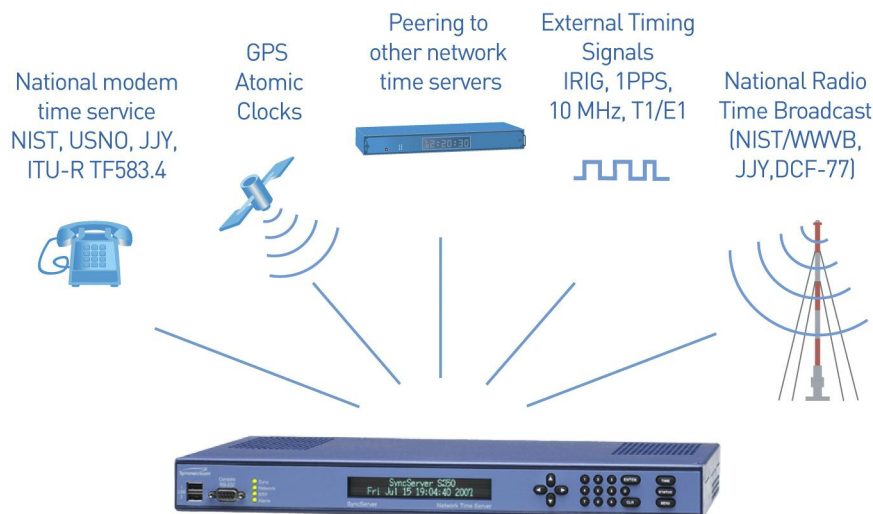

national time broadcasts, and works indoors or outdoors, anywhere or anytime the AM signal is detected.

Synchronize to Legal Time Sources

Serving time and synchronizing computers with time that is legally traceable to a national time standard is a requirement for many organizations. The internal dial-up modem in the S350 and the optional AM radio both provide that direct path to a national time source, thus assuring compliance.

Multiple Time Sources Assure Reliable Time

The SyncServer S350 continually monitors multiple sources of time and synchronizes to the most reliable, accurate or preferred. The GPS satellites are the most accurate and widely available source of time, but not the only source. The S350 can also use timecodes, 1PPS, 10 MHz, and T1/E1 inputs, NTP peering to other time servers over the network and the built-in modem to periodically dial national time services. In the event the preferred signal becomes unavailable, the S350 will immediately synchronize to the next user-prioritized source of time. In all cases the network administrator is notified immediately of any change in time reference status.

Improved Time Reliability with Different Access Paths

S350 time reliability starts with different paths to accurate time. The many paths include satellite, external timing signals, modem, and the network to provide redundancy should any one path become disconnected or unavailable. In addition, an optional AM radio provides a fifth path to official time broadcasts that are available in many areas. Also, an optional T1/E1 input can be used as a backup reference to other time sources.

Use Dial-Up or AM Radio when GPS is not an Option

Often a data center is located where GPS is not a viable option, such as a windowless basement of a tall building. The built-in modem on the S350 can provide dial-up access via analog phone line to the national time source maintained by many countries. Calls are made periodically and the frequency of the calls can be fixed or automatically optimized for accuracy. When used in conjunction with an optional OCXO or Rubidium oscillator, this solution offers a stable and reliable source of time for the network to rely on. Similarly, the optional AM radio can synchronize to



Internal modem and optional AM radio antenna provide access to national time sources for time reference redundancy.

Synchronize to Legal Time via AM Radio

All SyncServer S350s are Radio Ready to accommodate an optional AM radio/antenna from Symmetricom. National time authorities in the USA, Europe and Japan broadcast an AM time signal as an official source of time, and many common devices ranging from wall clocks to wristwatches synchronize to these broadcasts. Users can prioritize the national radio signal ahead of the GPS signal and use GPS as a backup.

BEST PRACTICES

- NTP protocol experts advise that time servers should have at least two sources of time, three is better, and four or more is best.
- Dial-up and radio broadcast signals are also direct connections to legal sources of time.
- Access and availability of time should be a consideration in every network design.

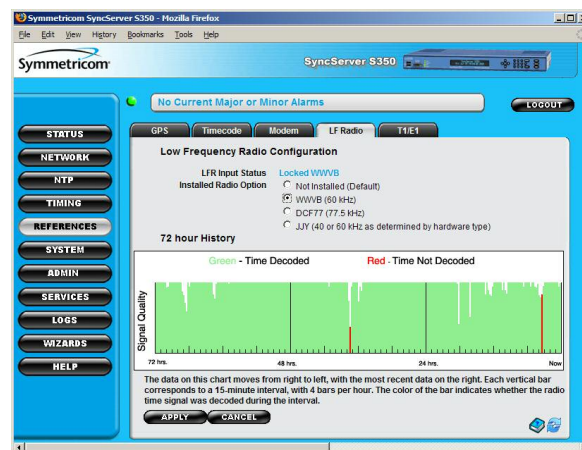

S350 PERFECT TIMING

Best-in-Class Timing Accuracy

The Stratum 1 level S350 derives nanosecond accurate time directly from the atomic clocks aboard the GPS satellite system. By using an integrated, 12-channel GPS receiver, every visible satellite can be tracked and used to maintain accurate and reliable time. While tracking GPS the S350 is accurate to 50 nanoseconds to UTC. Beyond accurate NTP time stamping, this precision is excellent for generating the standard timecodes, 1PPS, 10 MHz outputs and the optional T1/E1 signals. Time code inputs/outputs include IRIG A/B/E/G/NASA36/XR3/2137 in AM and DCLS formats.

Ultra High Performance NTP

The very high speed S350 NTP processor can effortlessly support hundreds of thousands of network clients while maintaining microsecond caliber NTP timestamp accuracy. NTP request throughput rates exceed 7000 requests/second while maintaining NTP timestamp accuracy. This easily translates into 0.5-2 ms typical client synchronization accuracy on a LAN.

Versatile Timing Configurations

The S350 automatically synchronizes to GPS, Timecodes, 1PPS, 10 MHz and the optional T1/E1 and/or AM radio reference in a user specified priority. It smoothly transitions from one reference to the

next one available if the higher priority signal is lost or regained. This is perfect for operating with different backup time or frequency sources.

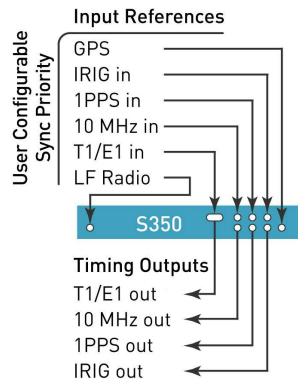

A Rubidium or Cesium atomic frequency reference is often desired as a back-up to GPS. With the optional Rubidium oscillator, the S350 will discipline the Rubidium and lock to it if other references are lost. Similarly, the S350 will seamlessly lock to the 10 MHz output of an external Cesium standard. Alternative timing configurations include peering the S350 to other user designated time servers and national dial-up time sources as fallback time references.

Time Cross-Checking for Peace of Mind Reliability

The S350 can time cross-check all reference time sources against at least two other time servers. This protects against an improperly operating reference that can subtly corrupt the time.

Flexible Control Over System Timing Inputs and Outputs

By protocol definition, the S350 serves NTP in the UTC timescale (or optionally in GPS timescale). However, the S350 can display local time rather than UTC on the front panel. The time can also be set manually with an override on the NTP alarms so that it behaves as though it is tracking a legitimate time source, even though it is actually in holdover.



Sysplex Timer for Mainframe Sync

A dedicated Sysplex timer port outputs serial time strings for IBM mainframe Sysplex systems. The Sysplex Timer provides a common time reference across all the members of an IBM Sysplex. The Sysplex Timer is a key component when systems on multiple CPCs share access to the same data.

Oscillator Upgrades Improve Holdover Accuracy and Save You Valuable Time

The standard S350 is equipped with a temperature compensated crystal oscillator (TCXO) that keeps the S350 accurate to nanoseconds when tracking GPS. However, if all time references are lost, thereby placing the server in holdover, the TCXO will soon drift away from perfect. Upgrading the oscillator improves the holdover accuracy significantly. For example, consider the drift rates below:

Oscillator	Holdover Drift
TCXO	18 milliseconds per day
OCXO	1 millisecond per day
Rubidium	3 microseconds per day

The value of the upgraded oscillator is that if the time references are lost, the S350 can continue to serve very accurate NTP time and maintain the output timing signals. This provides the IT staff plenty of time to correct the problem with no degradation or disruption in network time synchronization accuracy.

BEST PRACTICES

- Remember that accurate synchronization is directly related to how often the time clients update their time from the time server.
- Peering with other time servers is easy and provides a redundant source of time as a fallback.
- The optional Rubidium oscillator keeps the S350 extremely accurate while serving NTP in the event GPS service is interrupted.

Accumulated Drift Error by Oscillator Type

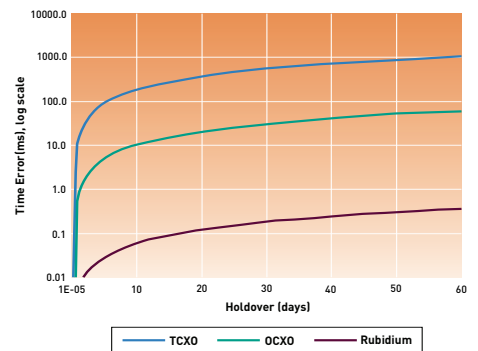

Plot of time error in milliseconds accumulated during holdover for different oscillator types. Note log scale of Y-axis.

S350 UNRIVALED SECURITY

A Security Architecture

The S350 is carefully architected for security via the multiport configuration. The web-based management interface is enabled only through Port 1 so that the administrator may choose to keep that port IP address private and secure. Only the time protocols can be served via Port 2, 3 and/or GbE. Time can also be served from Port 1.

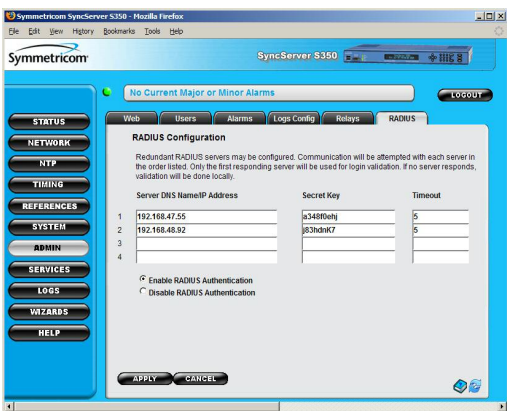

Management Access Security

Access to the web interface can be configured to pass through a variety of security measures including access control lists, passwords, RADIUS authentication, and SSL encryption for maximum security. RADIUS in particular provides excellent security and easy password management, particularly when there are multiple administrators that need access to the server. Individual protocols such as telnet, SSH, etc. can be disabled to further reduce open ports and running daemons in the server. Locally, the keypad on the server can be password protected to prevent tampering.

User Access Security

Aside from configuring the multiple ports for different network segments, unique access control lists per port can govern server response to client requests for time.

Server/Client Authentication

Authentication is valuable to assure that time is being retrieved from the correct time server and not being spoofed in some way by an imposter or man-in-the-middle. The S350 supports the two NTP authentication protocols, MD5 and Autokey. Generally, authentication is used between critical time clients and the time server or between NTP peers across a WAN where trust is very important. MD5 symmetric key cryptography is reasonably easy to deploy between clients and servers and is used to verify NTP packet integrity. Symmetricon's state-of-the-art Autokey implementation is based on public key cryptography and is more sophisticated in its deployment. Autokey verifies both packet integrity and packet source using digital signatures. The S350 supports Autokey as a server and/or a client.

Time Reference Security

The best way to assure the correct time is to have multiple, trusted time sources. The standard S350 supports satellite based GPS, multiple external timing signals such as IRIG, dial-up modem access to national time sources and network peering to trusted time servers. The NTP daemon continuously evaluates all configured time sources and rejects outliers. In addition, the

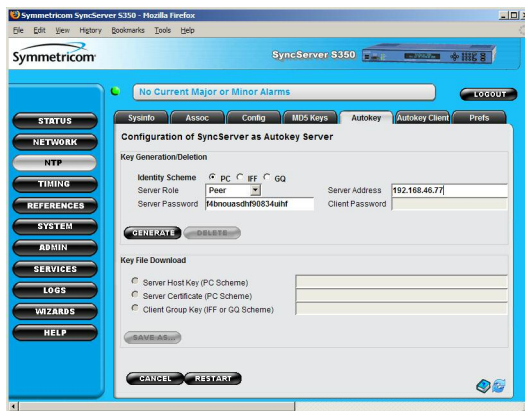
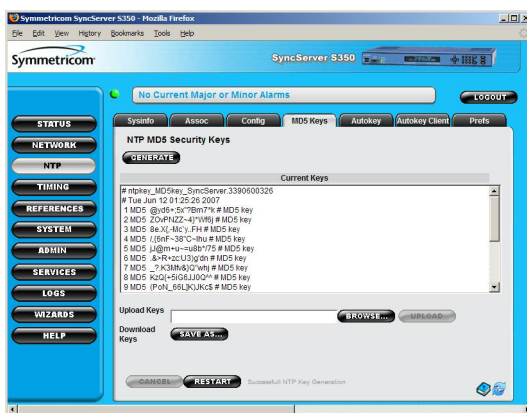

optional AM radio for the S350 synchronizes to government-maintained radio time broadcasts available across the U.S., Europe and Japan.

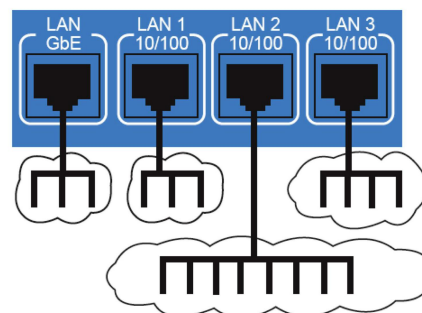

The Multiport configuration of the S350 with management on LAN 1 only is an excellent security measure and time distribution strategy.

BEST PRACTICES

- Always change the factory set password. Use RADIUS authentication if available.
- Keep the management port IP address private or exclusive. Use the three other ports to serve time to the network at large.
- Use access control lists on one or more ports to block unauthorized IP addresses.
- Lockout front panel keypad access to prevent unauthorized changes.

SyncServer S350 Specifications

NETWORK PROTOCOLS

NTP (v2 - RFC1119, v3 - RFC1305, v4 - No RFC)	SNMP v1, v2c, v3 (RFC3584)
NTP Unicast, Broadcast, Multicast, Autokey	MIB II (RFC1213)
SNTP Simple Network Time Protocol (RFC2030)	DHCP (RFC2131)
TIME (RFC868)	Telnet (RFC854)
DAYTIME (RFC867)	MD5 Authentication (RFC1321)
HTTP/SSL/HTTPS (RFC2616)	RADIUS (RFC2865)
SSH/SCP (Internet Draft)	SMTP Forwarding
	IPv4, IPv6 and IPv4/IPv6 Hybrid

Key management protocols can be individually disabled.

LAN 1: Management & Time protocols; LAN 2, 3 & GbE: Time protocols only.

SERVER PERFORMANCE

- 7000 NTP requests per second while maintaining accuracy associated with reference time source. The accuracy is inclusive of all NTP packet delays in and out of the SyncServer as measured at the network interface. Client synchronization accuracy to server on a LAN is 0.5 - 2 milliseconds (typical). The SyncServer easily supports many hundreds of thousands of NTP clients. NTP request handling capacity remains the same regardless of Stratum level.
- Stratum 1 via GPS: Overall time stamp accuracy of 7 microseconds to UTC with a variation of less than 42 microseconds typical
- Stratum 1 via Dial-up modem: <50 milliseconds to UTC (<20 ms typical).
- Stratum 2: Peering can be used as the primary mode of operation or as a back up mode in case the primary reference signals are lost. Time stamp accuracy depends on NTP peer server(s).
- Holdover Accuracy/Oscillator Aging

TCXO (standard):	18 milliseconds/day	<1E-06/month
OCXO (optional):	1 milliseconds/day	<1E-07/month
Rubidium (optional):	3 microseconds/day	<5E-11/month

GPS RECEIVER/ANTENNA

- 12 channel parallel receiver
- Minimum number of satellites for time: 1 intermittently
- GPS time traceable to UTC (USNO)
- Accuracy: <50 ns RMS, 150 ns peak to peak to UTC, ≥4 satellites tracked.
- Maximum Belden 9104 cable length: 150' (45 m). For longer cable runs see Options.

INTERNAL ANALOG MODEM

- Telecom approved in more than 50 countries
- Time Encoding: ACTS, JYJ, and ITU-R TF583.4

MECHANICAL/ENVIRONMENTAL

- Size: 1.75" x 17" x 11.25"
(4.5 cm x 43.2 cm x 28.6 cm) 1U rack mount
- Power: 100-240 VAC, 50-60 Hz, 25 watts
(45 watts with Rb osc.),
- Operating temperature: 0°C to +50°C
- Storage temperature: -10°C to +70°C
- Humidity: To 95%, noncondensing
- Certifications: FCC, CE (RoHS), UL, PSE, China RoHS
- Server weight: 9 lbs (4.1 kgs), Shipping package: 16 lbs (7.3 kgs)

Front Panel

- Display: Sharp, high-resolution 32x256 dot-matrix vacuum-fluorescent. 1, 2 or 4 line.
- Keypad: 0-9 numeric, up, down, left, right, ENTER, CLR, TIME, STATUS, MENU. Keypad lockout.

LEDs (tri-color green/red/orange)

Sync:	Time reference status
Network:	Network connection status
NTP:	NTP activity
Alarm:	Fault condition
Serial:	DB9-F 9600, N, 8, 1
USB:	For back up, restore, and upgrade operations.

Rear Panel

Network (4x):	1x RJ-45 10Base-T/100Base-TX/1000Base-T Gigabit Ethernet
	3x RJ-45 10Base-T/100Base-TX Ethernet
	Speed/Duplex: Auto, 10/full/half, 100/full/half
Sysplex:	DB9-M RS-232
GPS:	BNC L1, 1575 MHz
IRIG in:	BNC IRIG A/B/E/G/NASA36/XR3/2137/IEEE-1344 AM: 1V to 8V p-p, Zin >5KΩ DCLS: <1.5 V for logic 0, >2.0 V for logic 1
IRIG out:	BNC IRIG A/B/E/G/NASA36/XR3/2137/IEEE-1344 AM: Ratio 3:1 ±10%, Amp: 3.5 ± 0.5 Vpp, Zout 50Ω DCLS: <0.8 V for logic 0, >2.4 V for logic 1, Zout 50Ω
1PPS-in:	BNC Rising edge active, TTL into 270Ω
1PPS-out:	BNC Rising edge on-time, TTL into 50Ω
10 MHz-in:	BNC Sine wave or square wave, 1Vpp to 8Vpp, Zin >50KΩ
10 MHz-out:	BNC Sine wave >3Vpp & <4Vpp into 50Ω Sine wave >6Vpp & <8Vpp no load
Modem:	RJ-11 analog phone jack
Radio:	BNC, Optional antenna required for operation.
Power:	IEC 320 connector & power switch.
Relays:	2x, SPDT (Form C).

CLIENT SOFTWARE

Included with the S350 is Symmetricom's SymmTime NTP client for Windows. See Options for comprehensive software solution.

PRODUCT INCLUDES

S350 Network Time Server, L1 GPS antenna, 50' (15 m) Belden 9104 coaxial cable, 1 ft. antenna mounting mast (30 cm) with two clamps, category 5 patch cable, DB9-M to DB9-F RS-232 extension cable, manual, SymmTime NTP client for Windows, Enterprise MIB software, power cord, and rack mount ear kit. Two-year warranty.

OPTIONS

(See Options datasheet at http://www.ntp-systems.com/pdf/DS_SS0pts.pdf)

- Rubidium or OCXO oscillator upgrade for extended holdover
- AM Radio/Antenna (40, 60 or 77.5 kHz) for WWVB (USA), JYJ (Japan) or DCF77 (Europe)
- T1/E1 Input/Output (OCXO or Rubidium oscillator required to meet G.811 specification)
- ±40-60 Vdc power supply
- Window mounted GPS antenna
- GPS antenna in-line amplifier for cable runs to 300' (90 m)
- GPS antenna down/up converter for cable runs to 1500' (457 m)
- Lightning arrestor
- Comprehensive time client, server & management software for easy distribution, management and monitoring of time across the network.
- NTP Network Time Displays, 2" or 4" (5 cm or 10 cm), 6 digit, red LEDs



Rear View



Front View



SYMMETRICOM, INC.
2300 Orchard Parkway
San Jose, California
95131-1017
tel: 408.433.0910
fax: 408.428.7896
info@symmetricom.com
www.symmetricom.com